

General

Industrial and commercial water and wastewater customers shall advise the CBPU when they make in-house alterations which may affect their water usage or discharges to the sanitary sewer. These alterations may involve changes in volume and/or contaminants in the wastewater.

Permits:

No work of installing, replacing, connecting, extending, or altering any piping, fixtures, or other appurtenances that are in any way connected with or served by the water or sanitary sewer systems of the CBPU shall be performed except that at all times the State/County plumbing code is followed. The owner or his properly Licensed Master Plumber is responsible for the taking out of all permits, rendering of all reports, and the payment of all fees in conjunction with the given work.

Exception to the above may be had when persons, who are both owner and resident of their property, are granted permission by the State/County Plumbing Inspector to act as their own plumber in the performance of such work on their own premises.

All such work is subject to inspection by the State/County Plumbing Inspector and/or City Building Inspector who are responsible for the integrity of the work within his limits and by the Inspector of the Coldwater Board of Public Utilities who is responsible for the integrity of the balance of the work.

No work of plumbing shall be started until all county, state, City and CBPU permits applicable thereto have been obtained. In making application for CBPU permits the applicant shall state in detail the work to be performed and when required to do so shall submit complete plans and specifications with his application.

No permits are necessary for the repair of leaks, replacing of pipes, replacing of fixtures, or for the unstopping of sewer and waste pipes, when no change in the number and type of water and/or sewer connections are involved.

Regulations governing the issuance of permits for tapping and connecting of house service piping and house drains will be found elsewhere herein.

Capacity Fee:

A one-time capacity fee may be levied for a new customer's water or sewer service. This fee shall be established by the Board and may be revised periodically as approved by the Board.

Number of Services to one Property:

No more than one water or house sewer service connection may be extended to serve a single property or residential dwelling unit except by special permission to do so, and then only when such services are maintained entirely free of any and all interconnections that may, at any time, by-pass any water main valve or otherwise result in disturbance to the normal operation of the water and/or sewer systems. The water service line must be run to each property or building independently from its own shut-off at the street to allow for control by the CBPU.

Residences may have a second water service to supply a metered sprinkling service.

Connection of Flowing and Automatic Devices:

Commercial and industrial customer connections for supplying water to fountains, irrigation systems, and area sprinkling systems, or to any type of continuous flowing, or automatically controlled device, shall be made only on premises where the entire supply of water is furnished through water meters.

Residential customers supplying water to free flowing devices, such as irrigation systems and fountains, must be metered. These devices may be metered separately from the main water meter. A metering inspection permit must be obtained from the CBPU prior to the installation of the meter. An application fee in the amount of ten dollars (\$10.00) will be charged with each permit issued to cover the expense incurred by the CBPU to make the necessary inspections. Failure to comply with this regulation will subject the customer to discontinuance of service.

Use of Water for Heat Pumps:

Municipally supplied water may not be used to supply the thermal requirements of heat pump type space heating and cooling.

Rules of Construction

General:

These rules of construction apply equally to work being installed new and to work of repair and replacement and are deemed to be cooperative with and accessory to that ordinance or code currently in effect.

Joint Construction:

Water service pipes and house sewer pipes may be laid jointly in the same trench if done according to existing State/County/CBPU regulations.

Water service pipes and metallic gas pipes may not be laid jointly.

House sewer pipes and gas pipes may not be laid jointly.

All jointly laid piping shall be so installed that it is in accordance with the State/County plumbing code.

Where separate trenches are required a horizontal separation shall be maintained which is in accord with the State/County plumbing code.

Excavation and Backfill:

No excavation shall be started until all permits, including street opening permits, have been obtained and the general layout of the work has been carefully planned and agreed upon.

All unusable paving material, large rocks, masonry, roots and other debris, removed during excavation, shall be segregated from the clean earth, usable sod and paving materials, and removed from the site. No such materials shall be used in the backfill.

The trench shall be carefully brought to grade with a minimum of excess excavation and a suitable bed for the pipe or pipes prepared from clean sand and gravel from which all large stones and debris has been removed.

After the pipe has been laid it shall be covered with carefully selected material solidly compacted for a distance of not less than one foot above its top, extreme care being exercised to prevent its disturbance and/or injury.

Excavation and Backfill: (continued)

The balance of the trench may then be filled and compacted for its entire depth by wetting, by tamping, or by combined wetting and tamping, suitable allowance being made for final settlement. The sod shall then be replaced and/or top soil and grass seed used to restore the grassed areas as near as possible to their original condition. Paved areas shall be treated with a temporary surfacing or otherwise, as directed by the City Department of Municipal Services pending final repaving by that department.

The CBPU may deny any utility service for failure to adhere to the above requirements.

Protection to Work and to Others:

Ample protection shall be provided for all persons having access to the working area. Protection during construction and protection against possible damage due to settlement or disturbance after construction shall be provided for all adjacent piping, trees, shrubs, walks, curbs, buildings and other structures.

Construction of Pits and Manholes:

Due to State and Federal regulations regarding confined spaces, the construction of pits and manholes is strongly discouraged for the installation of water and sewer meters, backflow devices, bypasses, etc.

When water/wastewater meters are installed in crawl spaces, the main valve and water/wastewater meter must be accessible from the outside of the crawl space.

Water/wastewater meters will not be installed in locations considered confined spaces or requiring the installer to crawl under buildings. These locations are an extreme hazard to the Board's personnel. Additional plumbing required, due to improper location, must be completed by the property owner or his or her plumber at the property owner's expense before the water/wastewater meter is installed.

Pits and manholes installed for use in connection with water and house sewer service lines shall be substantially constructed of masonry, with sidewalls not less than 6 inches in thickness, with suitable conical or reinforced concrete top slabs of ample strength to suit the greatest load to which they may be subjected, and with round cast iron manhole rings and covers of equivalent strength.

Manhole rings and covers shall have clear access openings of not less than 19 inches.

When required to do so, and in addition to the access opening above described, a similarly constructed round cast iron lamp hole ring and cover, with a clear opening of not less than 8 inches, shall be provided and placed as directed. Such openings to be installed for the purpose of meter reading, hand valve operation, etc.

Pits or manholes may be round, oval, square or rectangular, with a minimum clear inside dimension of 4 feet or more.

Construction of Pits and Manholes: (continued)

The customer shall provide a 1/2" rigid or intermediate metal type conduit from the interior of the meter pit or manhole to a point specified by the CBPU for the remote reader installation.

All equipment installed within each pit or manhole shall comply with CBPU requirements.

Water Supply Taps and Services

Permits for installing water taps and services shall be purchased by the property owner, or by a licensed master plumber representing the property owner at the CBPU general offices.

The size and location of water taps and service pipes, the size and location of water/wastewater meters that are to be used in connection therewith, and the time that such installations are to be made will all be determined by the CBPU in conference with property owner and/or his plumber.

No such installation shall be made during freezing weather or when there is frost in the ground except upon prepayment of a sum estimated as being necessary to defray the extra expense which may be incurred on account of such freezing weather or frost.

Water services for corner lots shall be tapped to the nearest watermain. By special request and upon prepayment to the CBPU of an amount estimated to represent the extra expense involved on account of the increased distance, permission may be granted for tapping to the farther watermain.

Fees for Water Taps and Services:

All fees for the installation of new water taps and services may be required to be paid in advance. Fees do not include costs to repair sidewalks and/or curbing.

A paved street is taken as any street which has been hard surfaced for any part of its width with brick, concrete, blacktop, or other similar materials, either with or without special gutter or curb and gutter, the paved street fee applying whether or not it is necessary to remove any part of the pavement in making the water tap or service installation.

FEES

For Installation in Unpaved Streets:

For a 3/4" tap with 3/4" service pipe -----	\$1,041.00
For a 1" tap with 1" service pipe -----	\$1,267.00
For a 1-7/16" tap with 1-1/2" service pipe -----	\$1,835.00
For a 1-7/8" tap with 2" service pipe -----	Cost
For 4", 6" and 8" tap and service -----	Cost

For Installation in any Blacktop Paved Street:

For a 3/4" tap with 3/4" service pipe -----	\$2,130.00
For a 1" tap with 1" service pipe -----	\$2,355.00
For a 1-7/16" tap with 1-1/2" service pipe -----	\$2,815.00
For a 1-7/8" tap with 2" service pipe -----	Cost
For a 4", 6" and 8" tap and service -----	Cost

Water Supply Taps and ServicesFor Installation in any Paved Concrete Street and/or Concrete Street with Asphalt Surface:

For a 3/4" tap with 3/4" service pipe -----	\$3,225.00
For a 1" tap with 1" service pipe -----	\$3,450.00
For a 1-7/16" tap with 1-1/2" service pipe -----	\$3,855.00
For a 1-7/8" tap with 2" service pipe -----	Cost
For a 4", 6" and 8" tap and service -----	Cost

Cost Recovery Fees:

On the streets where distribution mains have been installed, or other extensions were installed at the expense of the Water Dept., the cost for service connections will be based on the CBPU cost to install 6" watermain (in dollars per foot) which is revised from time to time. The connection fee to be collected is the revised cost at the time of connection.

The connection fee is calculated from the width of the property to be served, herein referred to as frontage. The connection fee is based as determined by the CBPU. For a property on a corner lot the frontage will be for the shorter side.

Enlarging or Relocating Water Taps and Services:

The fee for replacing a smaller water tap and service pipe with a larger one, or for the purpose of relocating the water service, shall be the same as the fee for a new tap and service, plus the cost of removing the tap and service being replaced. No credit will be allowed for any materials which may be recovered from the replaced service. This fee shall be borne by the customer.

New Construction Water Meter Sets:

When facilities are constructed by a contractor, the electric service may not be transferred from the contractor's name and the construction rate to the property owner's name and a different rate until such time as a water meter has been installed and the water turned on. In the case of residences, if the homeowner is also the builder, no residential electric service shall be established until such time as a water meter has been installed.

Residential Water Services:

All new construction of single or two-family residences, homes built on lots which have or had water service, and homes that change from wells to the public water supply shall be required to be metered. The CBPU will furnish a meter setting device. The setting device must be installed by the owner and/or the contractor to CBPU specifications. Water will not be turned on until the meter is properly set and inspected by CBPU.

Newly constructed duplex homes must have separate water services to each dwelling unit from the primary water main at the street.

Construction for water services to multi-customer buildings must have sufficient plumbing to isolate, meter and shut off each customer individually without interrupting service to the other customers.

Water Supply Taps and ServicesFrozen Water/Wastewater Meters:

CBPU water customers may be charged a service fee of \$25.00 plus the cost of parts to repair frozen water/wastewater meters.

Construction of Water Services and Metering:

Per the fee schedule, the CBPU will install a suitable main connection, a service pipe, and a curb stop or gate valve with an access box located at a point which would normally be placed between the sidewalk and the curb, shoulder, easement or right of way. From this point the plumber/owner shall install the house service pipe. Water service connections must be made only to watermains maintained by the CBPU. Water connection location must meet CBPU approval. Water connections for domestic use are prohibited from private fire protection systems. This requirement is necessary to provide better quality water for domestic use.

The customer's service pipe shall be equal in size or not to exceed one size larger than the pipe from the main, and shall be carefully installed in accordance with the best water works practice, with not less than 5 feet of earth cover for its entire buried length. If warranted the customer's service pipe can be smaller than the service from the main upon the approval of the CBPU. All new water services shall be 1" or larger.

Water service pipes shall be terminated with an approved valve in approved frost proof basements, cellars, pits or manholes, into which they are to be carried continuously at a depth of not less than 5 feet.

In houses and other buildings that are constructed without basements or cellars and where adequate provision can be made for protection against freezing even should the building be unheated for extended periods of time, the following alternate method of terminating house water service pipes is permissible.

The house service pipe shall be run in under the floor slab of the building at a depth of not less than 5 feet. It shall then be brought up through the floor slab, with a long bend, and terminated with an approved valve located not less than 6" or more than 10" above the floor. All required frost protective measures shall be installed at the time the service pipe is placed and before the work is finally approved for use.

Each new or rebuilt water service shall be provided with metering connections adjacent to the valve. Provision shall be made for a meter placement for each unit of building occupancy and each such meter placement shall be provided with its own valve in addition to the main valve.

Meter bars or horns will be furnished by the CBPU, for installation with all new and rebuilt water services. Meter or meter bar installations must have one valve before and one valve after the meter or meter bar. Such services will not be turned on until the meter bar is installed properly.

Water Supply Taps and Services

Construction of Water Services and Metering: (continued)

All entrance and meter piping shall be carefully installed in a neat, workmanlike manner and shall be adequately supported so that no undue strains may be placed upon the pipes, valves and/or meters.

Minimum clearances must be maintained between the back wall and wall side edge of meter being installed. There must also be a minimum clearance of 6" from the bottom of each meter to the floor and a maximum height of 48" from the floor.

All water/wastewater meters are to be installed as close as is practical to the main shut-off valve inside the building. The main valve itself is to be located as close as practical to the point of entry into the building.

The following clearances must be maintained for proper installation of water/wastewater meters and meter bars:

Meter Size	Wall Clearance		Floor Clearance	
	Minimum		Minimum	Maximum
5/8 x 3/4"	4"		6"	48"
3/4"	5"		6"	48"
1"	6"		6"	48"
1-1/2"	7"		6"	48"
2"	8"		6"	48"
3"	9"		6"	24"
4"	10"		6"	24"
6"	12"		6"	24"
8"	14"		6"	24"

All new water meter installations three inches and above shall be furnished with a meter bypass. When a meter by-pass is installed the drawing below must be followed. There must also be a 16" clearance maintained over the meter if by-pass is installed above meter. No by-pass can be installed on front side of meter. The area below or behind meter is the preferred location for a by-pass. Water/wastewater meter installations 3" or larger in size may be furnished with a screen. The meter bypass shall be locked or sealed by the CBPU. If the seal is broken for emergency situations the CBPU must be notified immediately.

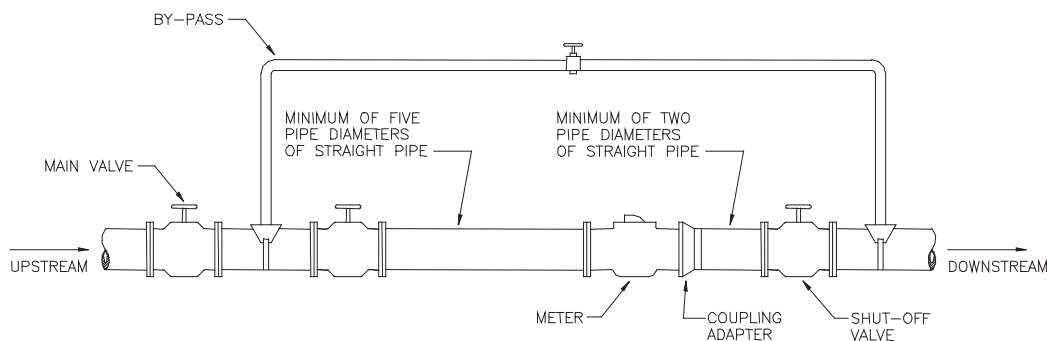

Water Supply Taps and ServicesConstruction of Water Services and Metering: (continued)

No water/wastewater meters shall be installed in basements, cellars, or pits that are not equipped with approved access ladders or stairs, nor in any manner that the meter reader will be required to lift excessively heavy manhole covers or other equipment or to climb into and out of difficult places and the area in front of meters must be kept clear at all times in order to gain access to them.

All water/wastewater meters in pits or manholes must be equipped with a remote reader.

Where a water service pipe enters through a basement, cellar, pit or manhole wall, or through a masonry floor, it shall be provided with an approved sleeve, properly joined and pointed with the masonry and thoroughly caulked with a suitable caulking mixture to form a good workmanlike protection for the pipe. Where the pipe enters through the floor the sleeve shall extend above the finished surface of the floor for a distance of not less than 4 inches.

The point of entrance of the water service pipe into the basement, cellar, pit or manhole shall be carefully selected as to suitability and shall at all times be kept free and clear of objectionable storage such as coal, wood, oils, waste materials, and similar items detrimental to the water service equipment and/or limiting access thereto.

Confined Space Water/Wastewater Meter Locations:

Water/wastewater meter installations in crawl spaces or other confined spaces must have CBPU location approval before installation of the water/wastewater meter.

Water Materials:

Materials for the construction of new and the replacement of old water supply services and private water systems are limited to the following, with full preference being given to a material selection harmonious with the CBPU's material selection for such construction from the main to the curb stop or gate:

1. Cold drawn, soft annealed seamless copper service pipe, in 3/4", 1", 1-1/2" and 2" sizes only, of proper bending temper, U.S. Government Type K, specification WW-T-799, with approved flanged, flared or soldered type bronze connections. Each run of pipe shall be, so far as practicable, in one continuous length free from joints and splices.
2. For 2" size and larger - copper service pipe of the type specified in (1) above, or American Water Works Association specification bell and spigot, mechanical, or push-on type joint ductile or cast iron watermain, designed for not less than 150 pounds water working pressure.

Water Regulations

Electric Continuity:

All water systems and services are required to be electrically continuous. Each pipe or fitting shall be electrically bonded to the adjacent pipe or fitting.

Taps and Services Under Paving:

Before any paving is laid or relaid in the City of Coldwater, the CBPU may, at its option, extend a suitable water service pipe to the sidewalk in front of each abutting property not then so provided, the owner of the property being charged with the tap fee that is applicable to such an installation in an unpaved street. If this fee is not paid upon installation, the tap fee charge may be increased to that fee applicable to a paved street, this increased fee to be paid in full before service may be taken from the connection so provided.

The CBPU shall in no way be held liable for failure to extend any water supply service in this manner preceding paving or repaving.

Water Leakage:

No water customer shall permit his water supply pipes, connections or fixtures to be out of repair so that water leakage can occur. Failure to do so may result in discontinuance of service. The CBPU may charge a customer an estimated amount for water wasted because of the leak if not repaired in a reasonable time.

The Board may, at its discretion, adjust a metered billing for water and wastewater due to an unknown leak on the customer's premises, after repairs have been made.

No water supply pipes, connections or fixtures shall be installed unprotected from frost, in unheated rooms or apartments, on outside uninsulated walls, or in any other manner so that water must be left running to prevent freezing.

Where water is used for filling tanks or other receptacles, an automatic float valve shall be provided so that when full of water the supply shall positively be cut off.

Pollution of Water Supply - Cross Connections:

The Michigan Safe Drinking Water Act, Act 399, P.A. 1976 prohibits cross connections with any public water supply.

See Section 1040.04 of the Codified Ordinances.

Water RegulationsCurb Boxes:

No unauthorized person shall open or attempt to open any curb or gate box. No unauthorized person shall cover or conceal any curb or gate box. At any time it is desired to change the surface grade near any curb or gate box the CBPU shall be given proper notice so that the box grade may be changed to correspond.

Operation of Fire Hydrants:

## 1. Private Hydrants

The operation by the owner of privately owned fire hydrants for other than fire fighting purposes is prohibited except when any one of the following requirements are met:

- a. Written permission is obtained from the Director of the CBPU.
- b. Verbal permission is obtained by the office of the Water Superintendent less than 12 hours prior to actual hydrant operation.
- c. Arrangements are made to have a CBPU representative present during operation.

In all cases a properly sized hydrant wrench must be used.

## 2. CBPU Hydrants

CBPU fire hydrants shall be operated by authorized personnel of the fire department, street department, and CBPU and such others as may be authorized by the Director of the CBPU from time to time.

When water is required for construction purposes, etc. and other means of obtaining water is not readily available, application may be made to the CBPU for use of water from an existing fire hydrant. It will be the responsibility of Board personnel to install a meter complete with sill cock for the attachment of a garden hose or fire hose, if applicable, on the fire hydrant and turn the hydrant on.

As soon as the use for which the meter was set is completed, Board personnel will close the hydrant, check for proper "drain back" and remove the meter.

It will be the responsibility of the person requesting the use of temporary water to pay for the installing, removing, the turning on and off of the hydrant and the water used and any damage, loss or theft which may result from such temporary use of hydrants.

Installation, removal, operation of fire hydrant - \$40.00 labor during normal working hours.

Water will be charged at the standard rates as published.

If more than one location is required, the same meter will be relocated and the above rate will apply to such location and installation.

Water Regulations

Use of Shut Off Keys:

No unauthorized persons are permitted to use operating wrenches, curb stop keys, or gate keys on any curb stop, gate valve or fire hydrant.

Cleaning of Service Pipes:

When water customers experience low pressure or stoppage of flow the CBPU shall take steps to restore proper service. Under the direct supervision of the customer's Master Plumber, the CBPU shall use the clean-out equipment necessary. The CBPU shall not be liable for any damage resulting from such cleaning of the water service. A homeowner may waive the requirement to have a Master Plumber present by signing a "release of responsibility" form.

Excess Pressure:

No person shall use any pump, ram or other device on any piping system connected with the water piping system, which is capable of producing a pressure in excess of the normal water pressure unless a representative of the CBPU is present and is in direct charge of the work.

Grounding of Electrical Circuits:

Where electric light and power circuits, communication circuits, and radio systems are grounded to the water service pipes, such connections shall be made mechanically and electrically secure and in accordance with the grounding provisions of the National Electrical Code.

All such ground connections shall be made to the service pipe where it enters the building and on the street side of the first valve or fitting.

Any person who removes such ground connection for work in or about the plumbing or electrical system of the building shall do so only after taking proper safeguards against the hazards involved and shall, upon completion of his work, reestablish such connections in accordance with the provisions outlined above.

Sprinkling and Other Use Limitations:

Except by special permit to do so, no unmetered customer shall operate or permit the operation of any lawn sprinkling device of any nature whatsoever between the hours of 10:00 p.m. and 4:00 a.m. or during such other hours as the CBPU may from time to time direct.

In the event of an emergency the CBPU reserves the right to place any restriction that it deems necessary on the use of city water, that the health, safety and other interests of the water users and of the water supply systems may be safeguarded.

Payment and Use of Water:

Water customers shall not use water for any other purposes than that for which payment has been made nor permit others to do so.

Disconnecting and Sealing:

Unmetered water rates on two family units are based upon the number of living units connected for use. When it is desired to avoid payment of the rate on any unit it is necessary to have the unit completely and effectively disconnected; or at the option of the customer, a water meter may be installed.

When, in the judgment of the CBPU, it is undesirable to require such a disconnection the CBPU may agree to seal or lock such units where the customer makes satisfactory provisions for such sealing or locking. Costs involved in such sealing or locking may be chargeable to the customer.

Any unauthorized breaking of any such seal or lock by or for the customer shall constitute sufficient ground for denying him further sealing and locking privileges and can subject the customer to a charge for the back billing of up to six months.

There may be situations where remodeling of the property is to such an extent that the extra unit is eliminated, while retaining some plumbing fixtures. When this has been accomplished, the property may be reclassified by the CBPU as a single family residence, after inspection by the CBPU and the approval of CBPU management.

Residential Metered Services:

If a meter horn or meter setting device is already present in the proper location, the CBPU will install the meter and run meter wire at no cost; otherwise the customer is responsible for installing a meter horn or meter setting device.

Any residential complex containing three units or more must be metered either individually or centrally metered to register all units.

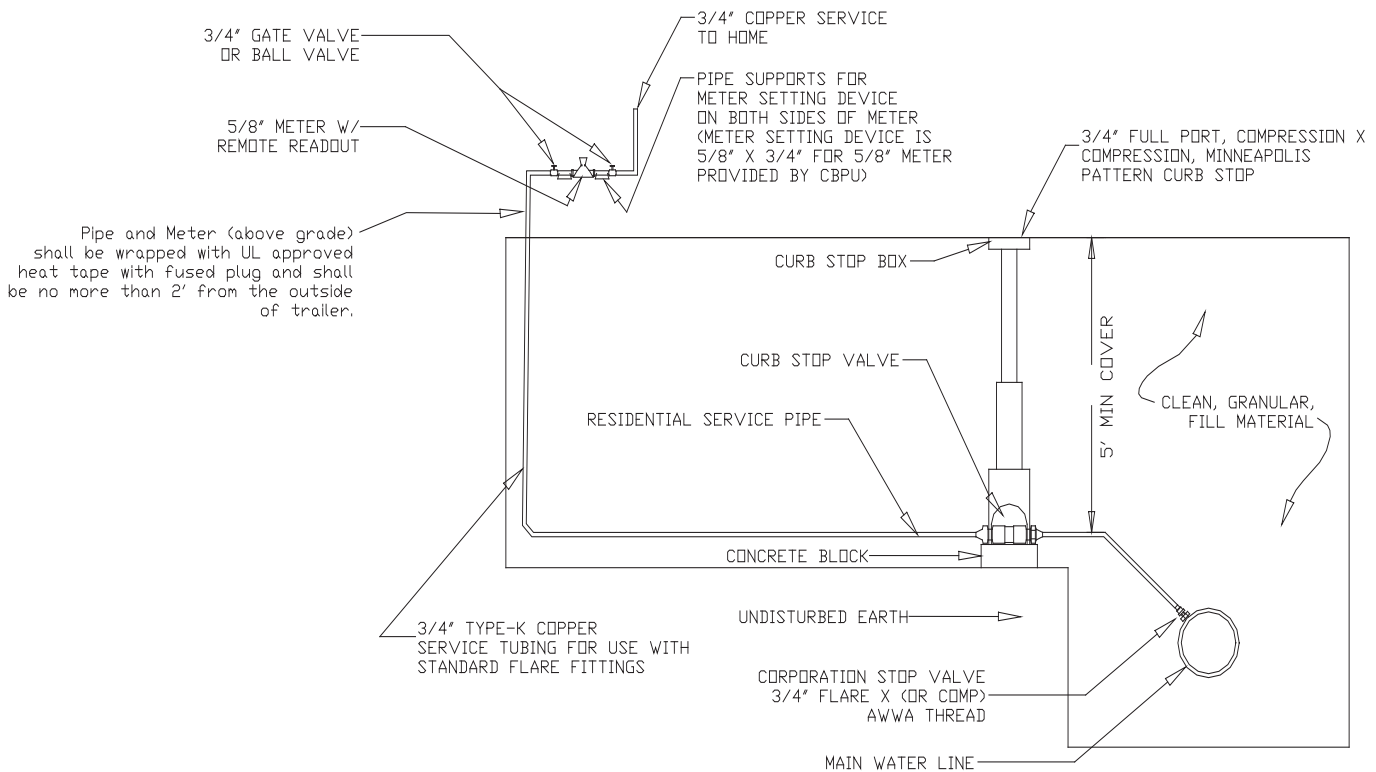

NOTE: RESIDENTIAL SERVICE PIPE SHALL BE TYPE "K" COPPER TO THE METER SETTING DEVICE W/ VALVES UPSTREAM & DOWNSTREAM OF THE METER CORPORATION STOPS SHALL BE A.W.W.A. APPROVED.

NOTE: CUSTOMER MUST PROVIDE 1/2" PLASTIC CONDUIT FROM THE WATER METER TO ELECTRIC METER PEDISTAL

NOTE: ALL PIPE & FITTINGS MUST BE ELECTRICALLY CONDUCTIVE

# INDIVIDUAL WATER SERVICE CONNECTIONS TO MANUFACTURED HOUSING

Watermain Extension Policy

Subject to the CBPU's specific approval for each such extension, watermains may be extended into areas not provided with watermains for the purpose of supplying fire protection and normal water service to the residents and property owners of such areas, provided that:

1. The water production, treatment and/or pumping facilities are ample and adequate to supply the additional quantity and quality of water, at pressures and rates of flow, that are anticipated as being required to properly supply the new area.

2. The transmission and distribution mains which will carry water to the new area are sufficient in size and capacity to do so without in any way deteriorating the water service to those presently connected and served by such mains.

3. Such watermain extensions will be made only in public streets and/or right of ways provided for public utilities and after acceptance by the CBPU, the water lines will become part of the public municipal system.

The CBPU may contract with sub-dividers to extend watermains in privately owned streets where such streets are for common use and/or may be destined at some future date to become public streets. However, all watermain construction must meet the specifications of the utility.

The sub-divider may also be required to pay the cost of CBPU inspection services or contracted inspection services in order to assure compliance with CBPU specifications.

It is the purpose of this section to prohibit the installation of watermains on privately owned properties with any part of the cost of such watermains being paid for by the Water Department. Extensions to supply fire protection service in factory yards, and to supply water service to properties built in off-street areas with private or semi-private entrance drives are included in this category.

4. This policy does not apply to watermain extensions to be made outside of the corporate limits of the City of Coldwater.

5. Except that the CBPU may especially contract otherwise, all watermains installed under this policy, even though cost of such installation may be borne in part or in total by others than the CBPU, shall be the property of the CBPU and shall be responsible for their operation, repair and maintenance throughout their life.

6. New residential subdivision developments may be charged the 8" watermain cost even though the CBPU may determine that larger mains are required for the hydraulic or other needs of the system.

7. The full cost of watermain extensions to other than new residential subdivisions shall be paid by the benefiting adjacent property unless the Utility Board of Directors determines that the increase in size is in the best interest of the Utility and its customers.

Watermain Installation Policy

Any contractor installing new watermain extensions to the Coldwater Board of Public Utilities' water system is prohibited from operating any gate valves, fire hydrants or other equipment. All requests for flushing of newly installed watermain, fire hydrants, fittings or related equipment must be requested at least three days in advance. Board employees shall perform all flushing of watermains and will coordinate work with contractor before such work will proceed. The Board reserves the right to restrict or reschedule the timing of this work due to other activities (i.e. hydrant flushing, freezing temperatures, etc.) occurring simultaneously.

The Board shall witness all pressure testing of newly installed watermain in accordance with American Water Works Standard C600-93. A copy of the successful test will be retained by the utility and a copy will be provided to the contractor if requested.

Monthly Charges for Flat Rate Water & Wastewater Service

	<u>Water</u>	<u>Wastewater</u>	<u>Total</u>
FLAT RATE RESIDENTIAL SERVICE	\$36.00	\$30.99	\$66.99

Availability:

Flat rate water and wastewater service is no longer available.

Unlisted Uses:

Rates for any use not listed herein will be specially computed or the entire service will be billed at metered rates.

Partial Period Billing:

Billing for flat rate water and wastewater service for partial months shall be calculated by prorating the amount on a daily basis.

Metered Water and Wastewater Rates  
To Be Billed Monthly

Application:

It is the intent of the CBPU that water sold to all users be metered and billed at the following rates.

Multiple Use:

It is required that the water piping in buildings of multiple occupancy be so arranged that the water supplied to each user may be separately controlled and metered at a central point - usually in the basement, in accordance with Section 1040.03 of the Codified Ordinances.

In existing residential properties, where this has not been done, a single meter may be installed to serve the several users jointly, in which case the readiness-to-serve charge for Water and Wastewater service shall be based on the number of such users times the readiness-to-serve charge. Mobile home parks, recreational vehicle parks and non-profit multiple housing projects are exempt from the Multiple Use Rule.

Readiness-to-Serve Charge -  
Meter Size:

	<u>Water</u>	<u>Wastewater</u>	<u>Total</u>
5/8 inch meter	\$12.35	\$14.99	\$27.34
3/4 inch meter	16.00	20.99	36.99
1 inch meter	22.00	37.49	59.49
1-1/4 inch meter	31.75	52.43	84.18
1-1/2 inch meter	48.50	69.54	118.04
2 inch meter	88.50	101.88	190.38
3 inch meter	195.00	191.46	386.46
4 inch meter	335.00	349.09	684.09
6 inch meter	550.00	776.91	1,326.91
12 inch meter	N/A	3,338.28	3,338.28

Consumption Charge:

The first 1,000,000 gallons used per month per 1,000 gal.	2.18	1.72	3.90
For all in excess of 1,000,000 gal. per 1,000 gal.	1.75	1.72	3.47

Sprinkling Readiness-to-Serve Charge -  
Water Meter Size:

5/8 inch meter	\$ 3.50
3/4 inch meter	\$ 7.50
1 inch meter	\$10.50
1-1/2 inch meter	\$23.25
2 inch meter	\$44.00

Consumption Charge:     \$ 1.85 per 1,000 gallons

A permit is required for the installation of all outdoor sprinkling systems and/or water wells.

Township Customers:

Township customers' rate is 150% of the established monthly City rate as referenced in the City of Coldwater/Township franchise agreements.

Fire Hydrant Water Meters:

Meter Size	Minimum Monthly Charge
3/4 inch meter	\$11.69
3 inch meter	\$85.96
Consumption Charge	\$1.99 per 1,000 gallons

Water Fill Station:

Water is available for filling tankers for construction, filling swimming pools, etc. at the water treatment plant. A \$10.00 charge will be assessed every time a tanker is filled, with a minimum charge of 1,000 gallons. The cost of the water is the same as the current metered consumption charge per 1,000 gallons. A deposit may be required at the time of filling. Water is available between the hours of 8:00 a.m. and 3:45 p.m. Monday through Friday. No tankers will be filled after 3:45 p.m. unless prior arrangements have been made.

Swimming Pools:

Pools will be filled during normal working hours. Cost is determined by the water used at published rates per 1,000 gallons plus \$120.00 for labor to fill the pool. Any pool filled after normal working hours is by special arrangement only and the labor cost will be \$180.00. The cost for pool filling will be invoiced to the service location utility bill.

Flushing or Lawn Sprinkling:

No credit will be issued for wastewater charges based on water consumed for lawn sprinkling or flushing from a fire hydrant which was registered by a meter utilized for billing combined water and wastewater consumption.

Dedicated Private Fire Protection Service Rate

Connections:

Owners or occupants of public or private, institutional, commercial and/or industrial properties who are regular customers of the Water Department may install and connect to the distribution system suitable pipes for the purpose of supplying water to private installations of fire hydrants and/or automatic fire protection sprinkler systems, for the protection of their property. No plastic or steel pipe will be allowed for underground water or fire protection systems.

All such installations shall require a permit and be in a manner acceptable to the CBPU and shall include a control valve located adjacent to the property line installed by the CBPU. Private fire protection services are required to extend from the public distribution system directly to the fire protection system with no intermediate connections for domestic use. No connections are allowed to any portion of a fire protection system to provide domestic water supply. All new water suppression lines will require a "detector check" to detect flow and must be wired to a remote reader.

The customer, at his own expense, shall furnish and install a Michigan DEQ approved reduced pressure backflow preventer on a dedicated or non-dedicated fire suppression line.

Installations involving not more than five conventional fire hydrants only, placed in the yards about the building, and which are so installed for the use and convenience of the Municipal Fire Department, not for use by the customer, may be made without a swing check valve, providing that nothing other than the fire hydrants are connected to the installation and all of these are so located that they may be readily inspected by the CBPU's representatives. No such installation shall have a supply pipe that is more than 8" internal diameter, or that is larger than the street main to which it is connected.

No service connection or cross connection of any sort shall be made to such fire protection installation for any purpose whatsoever.

Charges for Fire Suppression Line Flushing or Testing:

Charges for flushing fire suppression lines, testing fire booster pumps, etc., will be based on a pitot gauge reading.

The pitot gauge reading, in GPM, times the number of minutes the line is flushed or the pump is run, along with labor and equipment costs will be charged to the owner, contractor or fire sprinkler contractor.

CBPU personnel will take the pitot gauge reading. The CBPU will also provide documentation of calculated usage if requested.

Non-Dedicated Fire Protection Lines

Domestic/industrial service lines may be used for limited fire suppression systems when no more than 6 sprinkler heads will be connected.

When a domestic/industrial service line is used, the supply line for a fire protection sprinkler service shall be taken off the supply side of the water/wastewater meter. This line shall be provided with an approved gate valve for isolation purposes. The operation of this valve shall be the responsibility of the property owner.

Prior to connection of any limited area fire suppression system to any domestic/industrial service line, a permit shall be obtained from the CBPU. Permit approval shall be based on a usage/supply profile being approved by the CBPU and system plan approval by the City Building Department and CBPU Cross Connection Inspector.

The customer, at his own expense, must furnish and install a Michigan DEQ approved reduced pressure backflow preventer on a dedicated or non-dedicated fire suppression line.

The customer will provide and install before final inspection, labeling to be placed on the fire line with the wording "Fire Line - No Domestic Usage."

Rate:

The following monthly charge shall be made for all such sprinkler service installations. Service cost is determined by pipe size where it enters the building foundation.

For each 1/2" - 2-1/2" connection-----	\$ 3.40 per month
For each 4" connection-----	\$12.80 per month
For each 6" connection-----	\$28.75 per month
For each 8" connection-----	\$51.25 per month
For each 10" connection-----	\$79.50 per month
For each 12" connection-----	\$115.00 per month
Customer owned fire hydrants-----	\$16.30 per month

The above rates include the use of all water needed to fight fires, to drain and refill the system for testing purposes, and to care for normal non-preventable leakage that may accrue to the system.

CBPU Liability:

The Coldwater Board of Public Utilities assumes no liability for damages resulting from the turn off of any fire protection service for non-payment, repair or unauthorized use.

Fire Hydrants and Municipal Service Rate

	<u>Monthly Rate</u>
1. Fire Hydrants: Monthly charges per hydrant	\$ 16.30
2. Municipal Building Use: Coldwater Municipal Building, Public Safety Building, Municipal Services Dept., and other buildings of the General City Government that are supplied water and wastewater will be billed at the regular schedules for metered service as are other users of these services.	
3. Municipal Use (non-BOD): Municipal wastewater use for environmental remediation purposes where the disposal of virtually clean groundwater is required.	
Monthly Rate:	
Minimum Charge:	None
Consumption Charge:	
For all metered usage per 1,000 gal.	\$ .60

Sewer Taps and Building Sewers

General:

Historically, the sanitary sewers in the City of Coldwater were generally constructed by the City of Coldwater and turned over to the CBPU for operation and maintenance. Therefore, original construction quality, records and/or locations of sewers are in no way related to the judgments of the CBPU. THE CBPU ASSUMES NO LIABILITY FOR THE SAME.

Installing Sewer Taps:

Sewer tap connection and inspection permits may be obtained by the property owner and placed in the hands of a licensed master plumber, by an owner acting under State/County Permit as his own plumber, or by a licensed master plumber acting as agent for a property owner, upon payment of the proper fee.

Such information that the CBPU may have relative to sewer tap locations, lateral locations, sewer sizes and grades, are available to the public; however, the CBPU WILL ASSUME NO LIABILITY for the accuracy of such information.

Inspection Fees:

In addition to all regular and special assessments levied for sewer construction purposes, an inspection fee of \$35.00 shall be paid by every person making application for a new sewer tapping permit, this fee to cover the expense incurred by the CBPU in making the necessary inspection of the connection to the wye, stub lateral, manhole or main. All sewer inspection permits must be obtained prior to excavation or installation.

A similar fee shall be paid for similar inspections of sewers being rebuilt or relaid, involving reconnection to the City provided lateral, wye or manhole.

The applicant shall notify the CBPU immediately after connection when the sewer is ready for inspection. Failure to have the sewer inspected is a violation of Chapter 1042 of the Codified Ordinances and subjects the applicant to civil penalties and fines. Such violation will require the applicant to re-excavate the site of the connection for inspection and may result in additional inspection charges.

Connection Fees:

Properties which are not located within the limits of a special sewer assessment district and which have never been assessed for or otherwise provided with a sewer connection, may, by prepayment to the City Clerk of the sum that the City Council may set, be permitted such benefit providing that all expenses of construction of such connection be borne by the owner of that property. All of the details of such construction and connection shall be subject to the approval of the CBPU.

Sewer Taps and Building Sewers

Stubbing Laterals:

In connection with the construction of new sewers and with old sewers, prior to the paving or repaving of any street, the City Engineer or the CBPU, at their option, may extend such sewer taps or laterals that in their judgment appear necessary, from the main sewer to the curb. The entire cost of such work to be charged to the owner of the benefiting property, and the charges to be collected by special assessment in the event they remain unpaid for one year following their installation.

The CBPU shall in no way be held liable for failure to extend any sewer tap or lateral as outlined above.

Inspection of Sewer Connections:

In addition to assisting the property owner or his agent in planning the layout of each proposed new sewer connection the work will be given field inspections.

The inspection will be made at the time the connection is made with the wye connection, riser or lateral at the street sewer.

The owner or licensed master plumber named in the tapping permit shall notify the CBPU of the readiness of the work for inspection and the CBPU will within 24 hours, exclusive of Saturdays, Sundays and holidays, make such inspection as required.

The CBPU may, from time to time, make such other inspections of the work as are deemed necessary and upon disapproval of any part of the work by the inspector all work on the sewer shall be stopped until proper correction has been made and its approval obtained.

Point of Connection - Locating Wye:

Connections shall be made to the street sewer only at a wye or lateral which has been provided for the purpose. In the event that no such point of connection has been provided, that the connection cannot be found, or is found to be inaccessible, special permission may be issued by the CBPU to tap the main sewer with a new connection, the work of making such tap to be performed to the satisfaction of the CBPU's inspector.

In attempting to locate a wye or lateral connection an excavation shall be made at the point where the records indicate that a connection may be found, such excavation to extend not less than five feet in a dimension parallel to the main sewer and to a depth ample for the purpose. No part of the house sewer trench shall be excavated until the wye or lateral is found or it has been definitely established that it cannot be found.

Notice of Excavation:

A twenty-four hour notice must be given to the CBPU prior to excavating or tapping an interceptor main trunk sewer.

Sewer Taps and Building Sewers

Tapping a Vertical Riser:

Where it becomes necessary to tap a standing or vertical riser connecting with a deep sewer the following method of construction shall be employed:

The stopper shall first be removed and the riser carefully inspected by means of a light lowered through its entire length. If found defective the CBPU will repair or replace the riser before further work is performed.

On the top of the riser, with its branch turned to properly face the run of the house sewer, there shall be placed a wye-branch with one opening looking up. Vertically from this top opening there shall be installed a clean-out stack, the top of which, properly stoppered, shall be brought to the surface of the roadway.

It shall be the responsibility of the homeowner or contractor to construct the riser connection; however, the CBPU will provide the riser casting and cover. Maintenance of the riser will become the CBPU's responsibility after construction which will include normal repairs, root cutting and cleaning.

Construction of Sewers:

Building sewers shall be constructed of socket type premium joint vitrified clay tile, approved cast iron soil pipe, or S-40 PVC or PVC ASTM D3034 (SDR35) approved plastic pipe. The CBPU will consider other plastic pipe specifications on an individual basis. All installations shall be sized and constructed to meet the Plumbing Code and the CBPU's Rules and Regulations.

For all new construction, each individual dwelling/business shall have its own independent sewer lateral constructed from its own sewer wye connection at the main sewer.

The building sewer shall begin at the main sewer in the street, or at the end of the stubbed lateral provided for the purpose, and extend as near as possible in a straight line from that point to the point of connection with a clean-out opening just within the wall from which point the building sewer may be effectively rodded and cleaned for its entire length. The CBPU also encourages the installation of a clean-out just outside a building wall or foundation. Any pipe bends greater than 45 degrees shall require installation of a clean-out extended to the finished grade and easily accessible for maintenance purposes.

It is the owner's responsibility to insure the integrity of the existing lateral before connection is made.

The building sewer shall be carefully laid in a compacted bed of select material and shall be brought to grade by tamping under the pipes as they are laid, not less than three joints of pipe being left exposed continually as the work progresses for purposes of inspection and checking of grade, such exposed piping to be fully protected from injury and disturbance if the work is to be left unattended for any length of time. The interior of the pipe and the inside of the pipe joints shall be carefully cleaned as the work progresses and the opening in the pipe shall be kept continually closed with a stopper.

Sewer Taps and Building Sewers

Cast Iron:

Sewers constructed of cast iron shall meet all of the requirements of the Plumbing Code.

Plastics:

Sewers constructed of plastic must be S-40 PVC or PVC ASTM D3034 (SDR35) and comply with commercial standard to meet all requirements of the Plumbing Code. The CBPU will consider other plastic pipe specifications on an individual basis.

Concrete Work:

Concrete for encasement and support of sewer pipes shall meet the requirements of the Plumbing Code and CBPU approval.

Septic and Non-Septic Waste Disposal:

Septic and non-septic wastes that comply with the CBPU's septage receiving plan may be accepted for disposal at the wastewater treatment plant at the following rate. A deposit may be required at the time of dumping.

Septic and non-septic waste - \$.0901 per gallon

Trucked Waste:

The CBPU may accept trucked waste at its wastewater treatment plant, providing the material is compatible with the removal processes at the wastewater treatment plant. Prior approval and arrangements must be made before acceptance of any trucked material.

Charges for receiving and processing the waste material will be based on the current wastewater rates, strength and amount of material delivered. The CBPU reserves the right to require sample testing of the material.

Preventative Maintenance:

The CBPU may enter into an agreement with commercial, institutional, industrial or governmental customers to establish a preventative maintenance agreement and payment procedure for regularly scheduled maintenance/cleaning of sewer and storm water lines.

Sewer RegulationsSeparation of Sewers:

No roof water, surface drainage or storm water drainage from any point shall be admitted to or connected with any sanitary sewer. No sanitary sewer waste shall be admitted to or connected with any storm water sewer. The two systems must be kept entirely separate.

Prohibited Connection:

No sewer connection shall be made to any septic tank, privy vault, outhouse, cesspool, or to any source of prohibited waste, or directly with any part of the city water supply system.

Openings Below Ground Level:

Except as specified below no sewer openings or connections shall be installed below the overflow or relief point of any street sewer.

By special permission, closets, urinals, floor drains, laundry tubs, sinks and such other sewer connections as the CBPU may deem permissible may be installed below the overflow or relief point of any street sewer when each such connection is equipped with an approved readily accessible back-water valve, properly installed and properly maintained, so as to prevent the backing up of sewage in the event of stoppage, or that the fixtures be drained to an approved sewage sump which is equipped with proper venting and automatic sewage removal facilities.

Stoppage of House Sewers:

Removal of stoppages and repairs to house sewers is the responsibility of the property owners. In the event that trouble is found in the wye connection at the street sewer, or in vertical risers extending therefrom, the property owner shall establish that fact to the satisfaction of the CBPU who shall then cause proper repairs to be made at the expense of the CBPU.

The CBPU shall not be held liable for any expense incurred by the property owner in repairing or removing stoppages in house sewers or for any expense incurred by him in satisfying the CBPU that such damage or stoppage lies within that portion of the sewer system maintained by the CBPU.

The CBPU is not responsible for plumber/sewer cleaning contractor's expense incurred by property owner/renter for sewer backup on main sewer if the CBPU is not contacted prior to plumber/contractor being called.

Plumber/contractors are required to contact the CBPU whenever a customer's sanitary sewer lateral is being replaced within two feet of the mainline sanitary sewer. The CBPU will then have a representative present until all work within the concerned area is completed satisfactorily.

Grease Traps:

To insure protection of the municipal sewer system, commercial and/or institutional restaurants and food service customers may be required to install a grease trap.

Use of Sewers:

Refer to Chapter 1042 of the Codified Ordinances.